

FIG. 1

Signature

Vidya Bhaskar Singh Nandiyal
Patent Agent (IN/PA-2912)
Agent for the Applicant

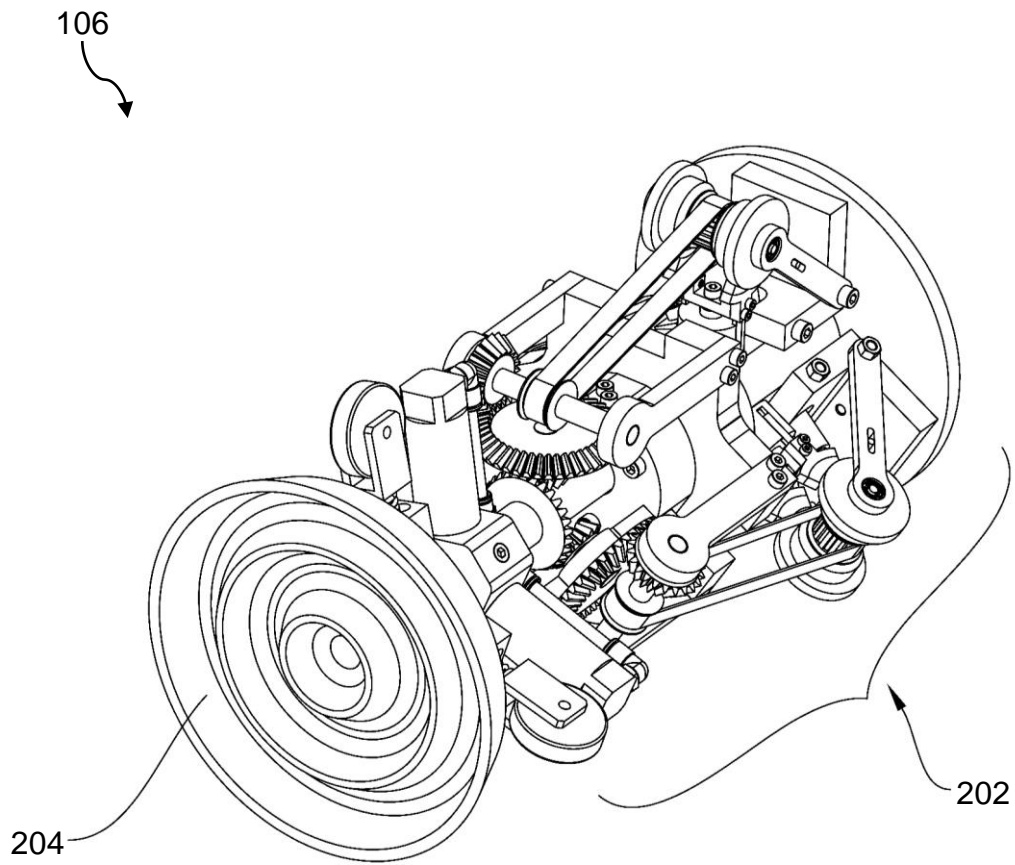

FIG. 2A

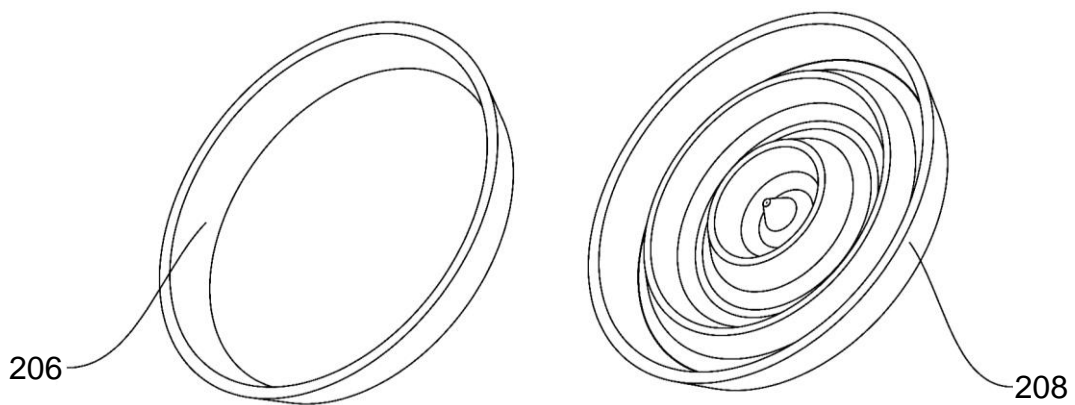

FIG. 2B

Signature

Vidya Bhaskar Singh Nandiyal
Patent Agent (IN/PA-2912)
Agent for the Applicant

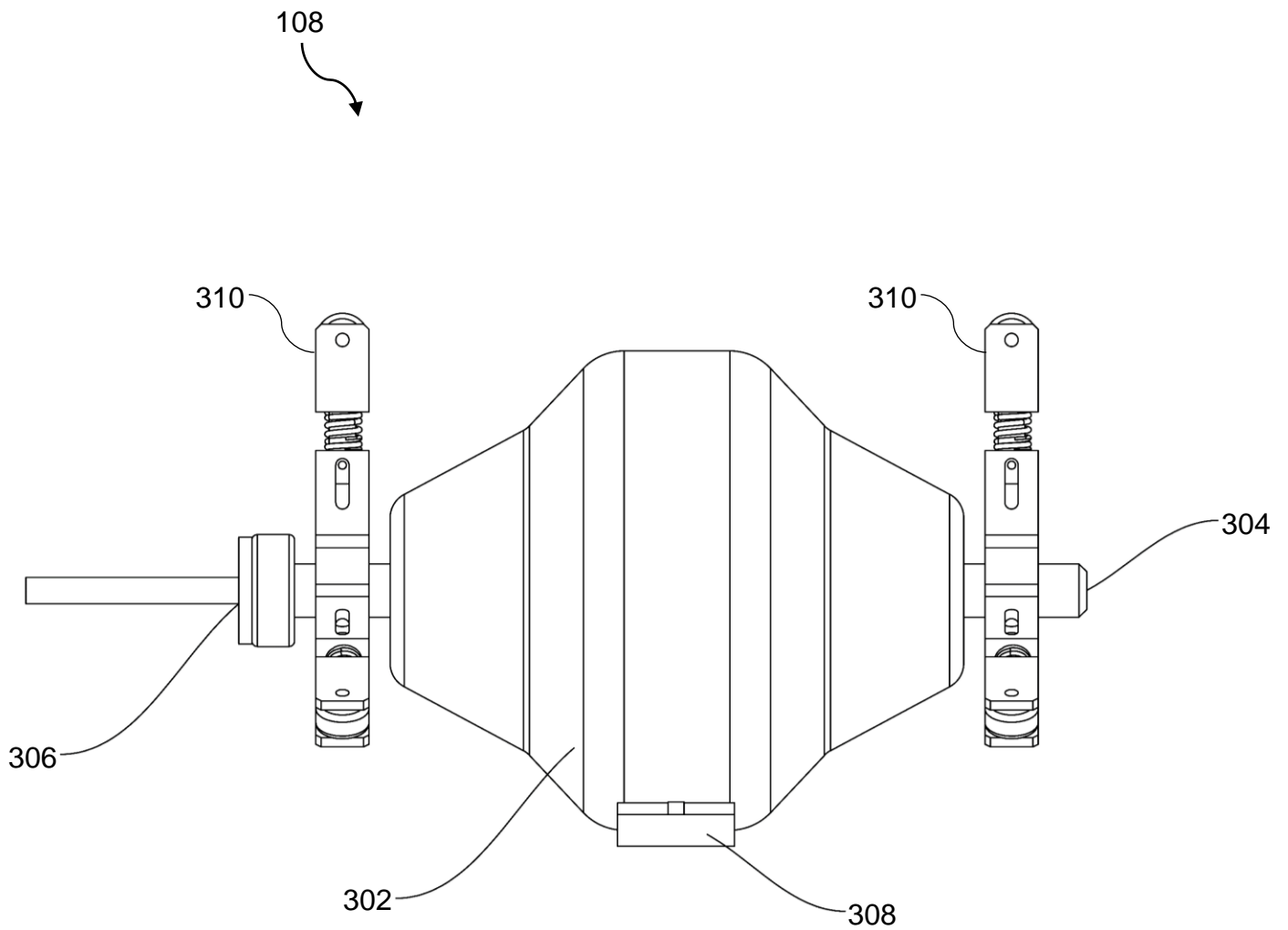

FIG. 3

Signature

Vidya Bhaskar Singh Nandiyal
Patent Agent (IN/PA-2912)
Agent for the Applicant

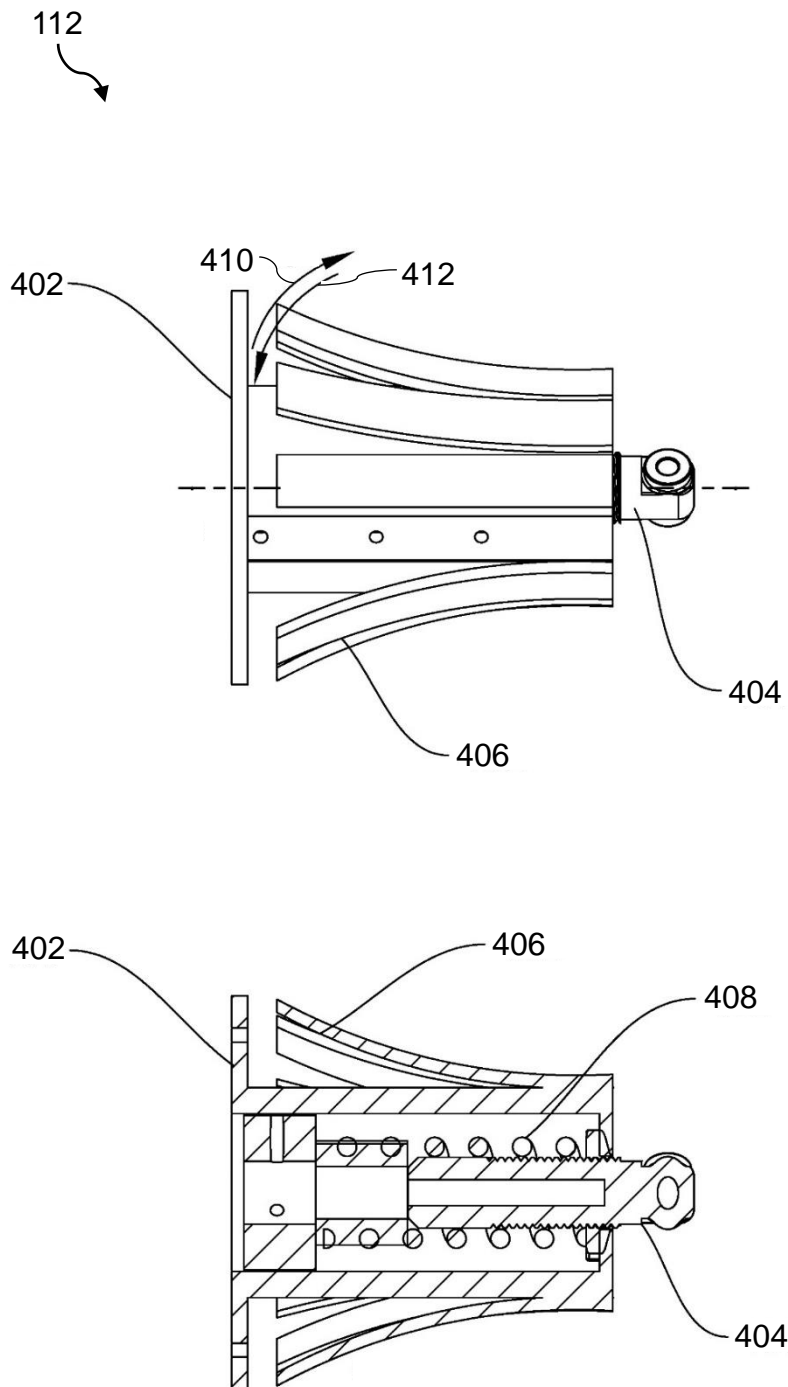

FIG. 4

Signature

Vidya Bhaskar Singh Nandiyal
Patent Agent (IN/PA-2912)
Agent for the Applicant

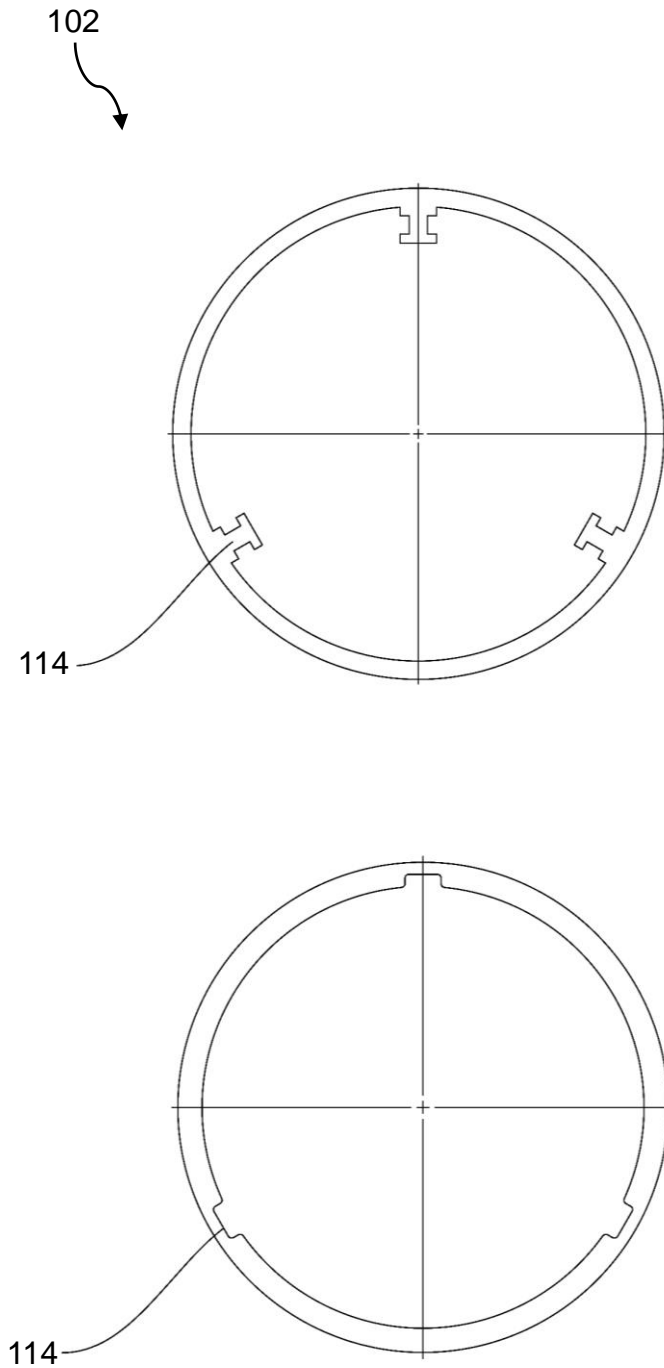

FIG. 5

Signature

Vidya Bhaskar Singh Nandiyal
Patent Agent (IN/PA-2912)
Agent for the Applicant

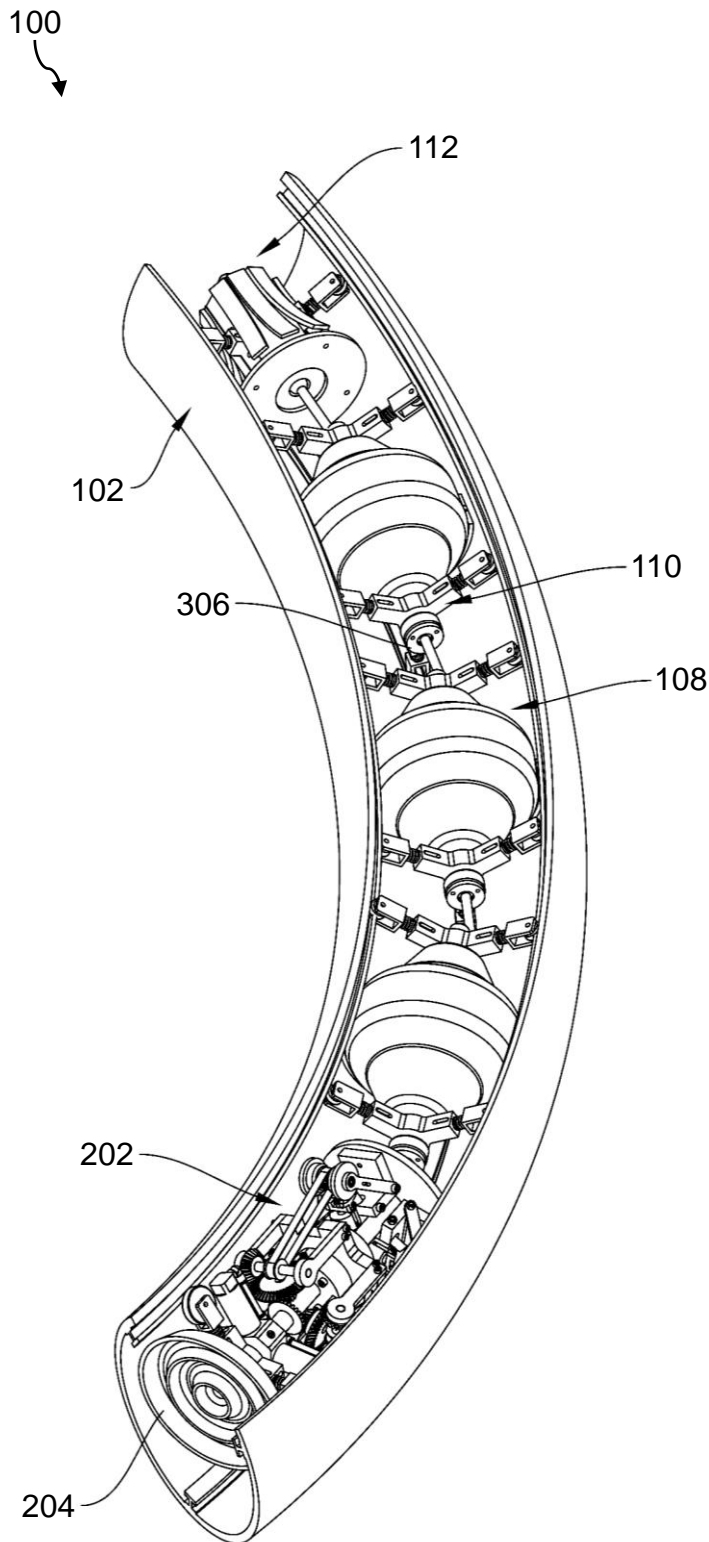

FIG. 6

Signature

Vidya Bhaskar Singh Nandiyal
Patent Agent (IN/PA-2912)
Agent for the Applicant

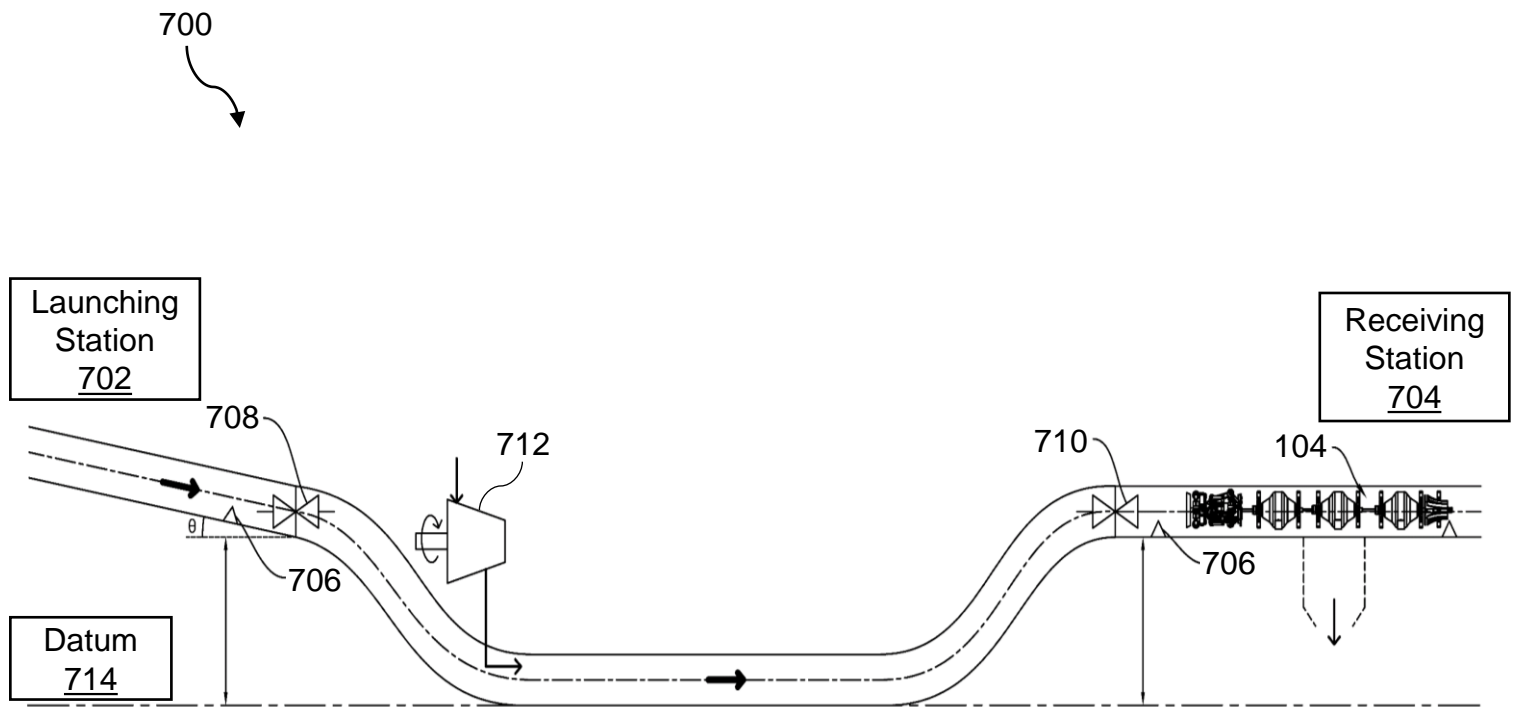

FIG. 7

Signature

Vidya Bhaskar Singh Nandiyal
Patent Agent (IN/PA-2912)
Agent for the Applicant

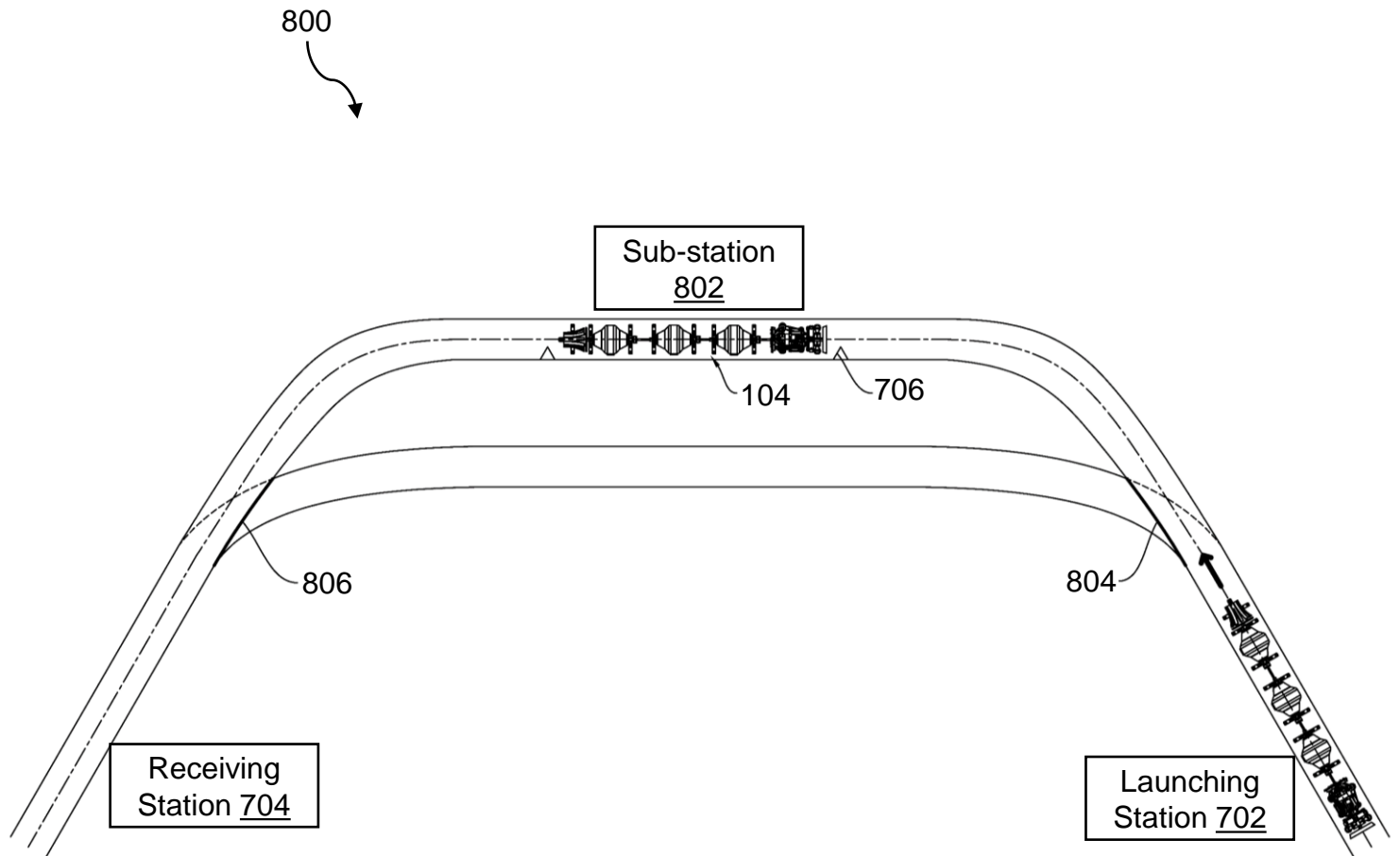

FIG. 8

Signature

Vidya Bhaskar Singh Nandiyal
Patent Agent (IN/PA-2912)
Agent for the Applicant

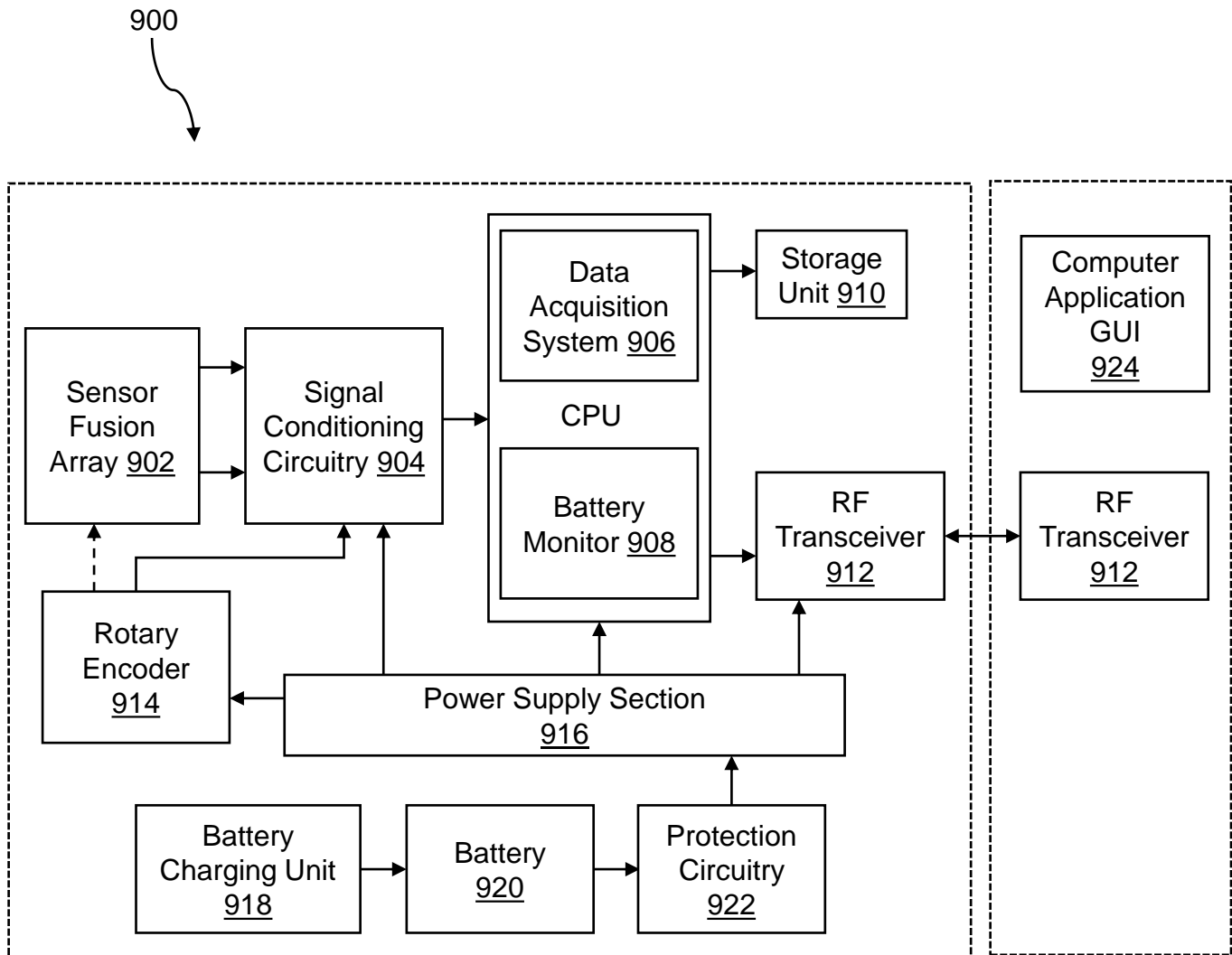

FIG. 9

Signature

Vidya Bhaskar Singh Nandiyal
Patent Agent (IN/PA-2912)
Agent for the Applicant

1000
↙



S.No.	Reference Numerals of Fluid Flow Deflectors (Ref. FIG. 2)	Types of Fluid Flow Deflectors	Maximum Pressure at the Fluid Flow Deflectors (Pa)	Pressure difference across pipe (Pa)
1	206		524.7	550
2	204		800.3	830
3	208		807	840

FIG. 10

Signature

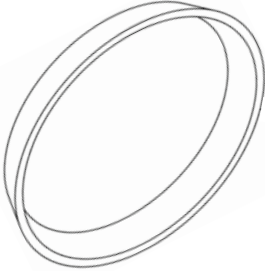

Vidya Bhaskar Singh Nandiyal
Patent Agent (IN/PA-2912)
Agent for the Applicant